

HD48XX - HD49XX SERIES



**HD4807T..., HD48V07T..., HD48S07T..., HD4801T...,
HD48V01T..., HD4817T..., HD48V17T..., HD4877T... HD48V77T...,
HD4907T..., HD4901T..., HD4917T..., HD4977T...**

PASSIVE OR ACTIVE TEMPERATURE, RELATIVE HUMIDITY, RELATIVE HUMIDITY AND TEMPERATURE, TEMPERATURE AND DEW POINT TRANSMITTERS

HD48.. and HD49.. series of transmitters measure temperature, relative humidity and the dew point temperature.

Versions with only standard analog output or with only RS485 output with **MODBUS-RTU** protocol are available. The models with analog output provide a signal suitable for transmission to a remote display, recorder or PLC. The models with RS485 output are suitable for connection to a PC or PLC.

The models of the **HD48.. series are active** transmitters and accept both direct and 24Vac alternating power supply; they have standard current (4...20mA) or voltage (0...10V) outputs, or a serial RS485 output, depending on the model. The models of the **HD49.. series are passive** transmitters and thus suitable to be inserted in a 4...20mA current loop. The HD48.. and HD49.. series of transmitters are designed for temperature and humidity control in conditioning and ventilation applications (HVAC/BEMS) in the following sectors: pharmacy, museums, clean rooms, ventilation ducts, industrial and civil sectors, crowded places, canteens, auditoria, gyms, high-density farms, greenhouses, etc.

The HD48.. and HD49.. transmitters measure relative humidity with a well proven temperature compensated capacitive sensor that assures precise and reliable measurements in the course of time. The transmitters of the HD48.. and HD49.. series are available in two probe temperature ranges: **standard -20...+80°C and extended -40...+150°C for the most critical applications**. A stainless steel 20µm filter protects the sensors against dust and particles (other filters are available for different applications).

The transmitters are factory calibrated and no further adjustments are required.

Each series is available in three different versions: with horizontal probe for duct mounting (HD48...TO..., HD49...TO...), with vertical probe for wall mounting (HD48...TV..., HD49...TV...) or with remote probe connected to the transmitter by means of a cable (HD48...TC..., HD49...TC...), cable lengths available are 2, 5 and 10m or for the measure of compressed air in pipelines (HD48...TP480, HD49...TP480). The probes can be supplied in two different lengths (135mm or 335mm).

Various accessories are available for the installation: for example to fix the probe to the duct, it can be used the HD9008.31 flange, a 3/8" universal biconical connection or a PG16 metal cable gland (Ø10...14mm). A 4-digit optional display ("L" model) allows to display the measured parameters in a continuous or sequential mode.

Technical specifications

| | | STANDARD RANGE | EXTENDED RANGE |
|--|-------------------|--|----------------|
| Relative Humidity | | | |
| Sensor | | Capacitive | |
| Measuring range | | 0...100%RH | |
| Accuracy @ T=15...35°C | | ±1.5% RH (0...90%RH), ±2.0% RH (90...100%RH) | |
| Accuracy @ rest of T range | | ±(1.5+1.5% of the measure) %RH | |
| Repeatability | | 0.4%RH | |
| Sensor working temperature | | -20...+80°C | -40...+150°C |
| Temperature | | | |
| Measuring range | | -20...+80°C | -40...+150°C |
| Sensor | | NTC 10kΩ | Pt100 class A |
| Accuracy | | ±0.3°C (0...+70°C) ±0.4°C (-20...0°C, +70...+80°C) | ±0.3°C |
| Repeatability | | 0.05°C | 0.05°C |
| Dew Point | | | |
| Sensor | | Parameter calculated from relative humidity and temperature | |
| Measuring range | | -20...+80°C DP | |
| Accuracy | | See table 1 below | |
| Repeatability | | 0.5°C DP | |
| Type of output (according to the model) | | | |
| Models HD4807T.. | Temperature | 4...20mA (-20...+80°C), R _i < 500Ω 22mA outside the measuring range | |
| Models HD4807ET.. | Temperature | 4...20mA (-40...+150°C), R _i < 500Ω 22mA outside the measuring range | |
| Models HD48V07T.. | Temperature | 0...10Vdc (-20...+80°C), R _i > 10kΩ 11Vdc outside the measuring range | |
| Models HD48V07ET.. | Temperature | 0...10Vdc (-40...+150°C), R _i > 10kΩ 11Vdc outside the measuring range | |
| Models HD48S07T.. HD48S07ET.. | Temperature | Only RS485 with MODBUS-RTU protocol | |
| Models HD4907T.. | Temperature | 4...20mA (-20...+80°C), R _i Max = (Vdc-12)/0.022 22mA outside the measuring range | |
| Models HD4907ET.. | Temperature | 4...20mA (-40...+150°C), R _i Max = (Vdc-12)/0.022 22mA outside the measuring range | |
| Models HD4801T.. HD4801ET | Relative Humidity | 4...20mA (0...100%RH), R _i < 500Ω 22mA outside the measuring range | |
| Models HD48V01T.. HD48V01ET.. | Relative Humidity | 0...10Vdc (0...100%RH), R _i > 10kΩ 11Vdc outside the measuring range | |
| Models HD48S01T.. HD48S01ET.. | Relative Humidity | Only RS485 with MODBUS-RTU protocol | |
| Models HD4901T.. HD4901ET.. | Relative Humidity | 4...20mA (0...100%RH), R _i Max = (Vdc-12)/0.022 22mA outside the measuring range | |
| Models HD4817T.. | Relative Humidity | 4...20mA (0...100%RH), R _i < 500Ω 22mA outside the measuring range | |
| | Temperature | 4...20mA (-20...+80°C), R _i < 500Ω 22mA outside the measuring range | |
| Models HD4817TV.. | Relative Humidity | 4...20mA (0...100%RH), R _i < 500Ω 22mA outside the measuring range | |
| | Temperature | 4...20mA (0...+60°C), R _i < 500Ω 22mA outside the measuring range | |
| Models HD4817ET.. | Relative Humidity | 4...20mA (0...100%RH), R _i < 500Ω 22mA outside the measuring range | |
| | Temperature | 4...20mA (-40...+150°C), R _i < 500Ω 22mA outside the measuring range | |
| Models HD48V17T.. | Relative Humidity | 0...10Vdc (0...100%RH), R _i > 10kΩ 11Vdc outside the measuring range | |
| | Temperature | 0...10Vdc (-20...+80°C), R _i > 10kΩ 11Vdc outside the measuring range | |
| Models HD48V17ET.. | Relative Humidity | 0...10Vdc (0...100%RH), R _i > 10kΩ 11Vdc outside the measuring range | |
| | Temperature | 0...10Vdc (-40...+150°C), R _i > 10kΩ 11Vdc outside the measuring range | |
| Models HD48S17T.. HD48S17ET | Relative Humidity | Only RS485 with MODBUS-RTU protocol | |
| | Temperature | Only RS485 with MODBUS-RTU protocol | |
| Models HD4917T.. | Relative Humidity | 4...20mA (0...100%RH), R _i Max = (Vdc-12)/0.022 22mA outside the measuring range | |
| | Temperature | 4...20mA (-20...+80°C), R _i Max = (Vdc-12)/0.022 22mA outside the measuring range | |
| Models HD4917TV.. | Relative Humidity | 4...20mA (0...100%RH), R _i Max = (Vdc-12)/0.022 22mA outside the measuring range | |
| | Temperature | 4...20mA (0...+60°C), R _i Max = (Vdc-12)/0.022 22mA outside the measuring range | |
| Models HD4917ET.. | Relative Humidity | 4...20mA (0...100%RH), R _i Max = (Vdc-12)/0.022 22mA outside the measuring range | |
| | Temperature | 4...20mA (-40...+150°C), R _i Max = (Vdc-12)/0.022 22mA outside the measuring range | |
| Models HD4877T.. | Dew Point | 4...20mA (-20...+80°C DP), R _i < 500Ω 22mA outside the measuring range | |
| | Temperature | 4...20mA (-20...+80°C), R _i < 500Ω 22mA outside the measuring range | |
| Models HD48V77T.. | Dew Point | 0...10Vdc (-20...+80°C TD), R _i > 10kΩ 11Vdc outside the measuring range | |
| | Temperature | 0...10Vdc (-20...+80°C), R _i > 10kΩ 11Vdc outside the measuring range | |
| Models HD48S77T.. | Dew Point | Only RS485 with MODBUS-RTU protocol | |
| | Temperature | Only RS485 with MODBUS-RTU protocol | |
| Models HD4977T.. | Dew Point | 4...20mA (-20...+80°C DP), R _i Max = (Vdc-12)/0.022 22mA outside the measuring range | |
| | Temperature | 4...20mA (-20...+80°C), R _i Max = (Vdc-12)/0.022 22mA outside the measuring range | |
| Models HD4877T480 | Dew Point | 4...20mA (-40...+60°C DP), R _i < 500Ω 22mA outside the measuring range | |
| | Temperature | 4...20mA (-40...+60°C), R _i < 500Ω 22mA outside the measuring range | |

| | | |
|--|--|---|
| Models HD48V77T480 | Dew Point | 0...10Vdc (-40...+60°C DP), $R_i > 10k\Omega$ 11Vdc outside the measuring range |
| | Temperature | 0...10Vdc (-40...+60°C DP), $R_i > 10k\Omega$ 11Vdc outside the measuring range |
| Models HD48S77T480 | Dew Point | Only RS485 with MODBUS-RTU protocol |
| | Temperature | |
| Models HD4977T480 | Dew Point | 4...20mA (-40...+60°C DP), $R_i \text{ Max} = (Vdc-12)/0.022$ 22mA outside the measuring range |
| | Temperature | 4...20mA (-40...+60°C), $R_i \text{ Max} = (Vdc-12)/0.022$ 22mA outside the measuring range |
| Power supply and electrical connections | | |
| | HD48.. | HD49.. |
| Power supply | 18...40Vdc or 24 Vac $\pm 10\%$ | 12...40Vdc |
| Consumption | - 4mA@24V (models with voltage output) - 4mA@24V with open output, 20mA@24V with 12mA output (models with standards output) - 2mA@24V models with serial RS485 output | |
| Electrical connections | Screw type terminal block, max 1,5mm ² , M16 cable gland for input cable | |
| General specifications | | |
| TV probe working temperature | -20...+80°C | |
| ...TO...TC Probes working temperature | STANDARD RANGE | EXTENDED RANGE |
| | -20...+80°C | -40...+150°C |
| T480 probes working temperature | -40...+60°C | |
| Storage temperature | -20...+80°C | |
| electronics protection class | IP66 | |
| Case dimensions | 80x84x44 | |

Table 1 -Accuracy of dew point measurement:

| | | TD °C | | | | | | | | |
|----------------|-----|--------------|--------------|----------------|----------------|--------------|--------------|--------------|--------------|--------------|
| | | -20 | -10 | 0 | 10 | 20 | 30 | 40 | 60 | 80 |
| Temperature °C | -20 | $\leq \pm 1$ | | | | | | | | |
| | -10 | $\leq \pm 1$ | $\leq \pm 1$ | | | | | | | |
| | 0 | $\leq \pm 1$ | $\leq \pm 1$ | $\leq \pm 1$ | | | | | | |
| | 10 | $\leq \pm 3$ | $\leq \pm 1$ | $\leq \pm 1$ | $\leq \pm 1$ | | | | | |
| | 20 | $\leq \pm 4$ | $\leq \pm 2$ | $\leq \pm 1$ | $\leq \pm 1$ | $\leq \pm 1$ | | | | |
| | 30 | | $\leq \pm 3$ | $\leq \pm 1,5$ | $\leq \pm 1$ | $\leq \pm 1$ | $\leq \pm 1$ | | | |
| | 40 | | | $\leq \pm 2$ | $\leq \pm 1$ | $\leq \pm 1$ | $\leq \pm 1$ | $\leq \pm 1$ | | |
| | 60 | | | | $\leq \pm 2,5$ | $\leq \pm 2$ | $\leq \pm 1$ | $\leq \pm 1$ | $\leq \pm 1$ | |
| | 80 | | | | | $\leq \pm 4$ | $\leq \pm 2$ | $\leq \pm 1$ | $\leq \pm 1$ | $\leq \pm 1$ |

For example at 20°C a Dew Point value of 0°C DP is measured with an accuracy better than 1°C DP.

Installation notes

To fix the probe inside a ventilation duct, a pipe, etc., use for example the HD9008.31 flange, a PG16 metal cable gland (Ø10...14mm) or a 3/8" universal biconical connection.

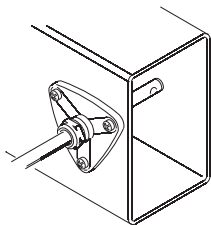

HD9008.31 Flange

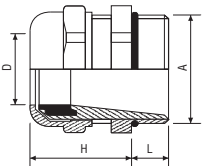

PG16 metal cable gland
D = 10...14mm
L = 6.5mm
H = 23mm
A = PG16

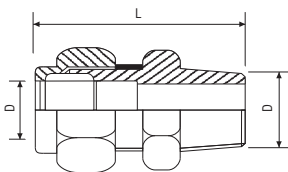

Universal biconical connector
L = 35mm
D = 14mm
A = 3/8"

Electrical connections

HD48.. series with analog output

Power the instrument as shown in the below connection schemes, the power supply terminals are marked as +Vcc and GND.

Depending on the model, the output signal is available between:

- Ta and AGND terminals for the transmitters of the HD4807T.. and HD48V07T... series.
- RH% and AGND terminals for the transmitters of the HD4801T.. and HD48V01T.. series.
- RH% and AGND, Ta and AGND terminals for the transmitters of the HD4817T.. and HD48V17T.. series.
- DP and AGND, Ta and AGND terminals for the transmitters of the HD4877T.. and HD48V77T.. series.

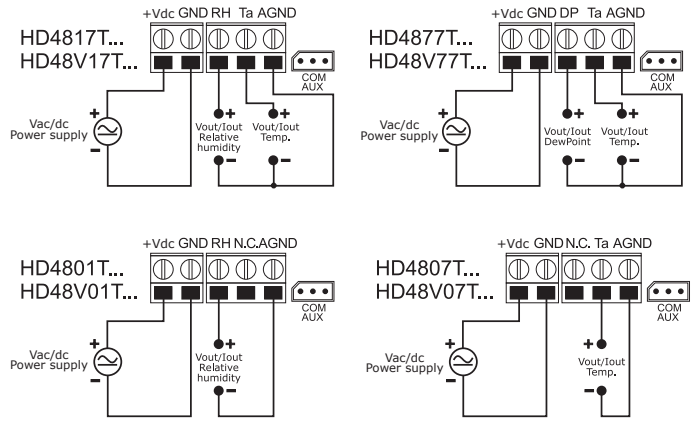

HD48...series with RS485 output

Connect the instrument as shown in the below connection schemes, the power supply terminals are marked as +Vcc and GND.

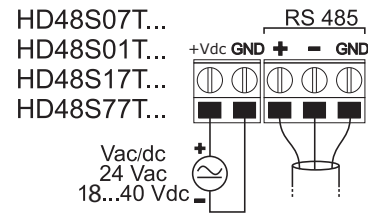

Thanks to RS485 output, several instruments can be connected to form a network. The instruments are connected in a sequence through a shielded cable with twisted pair for signals and a third wire for the mass.

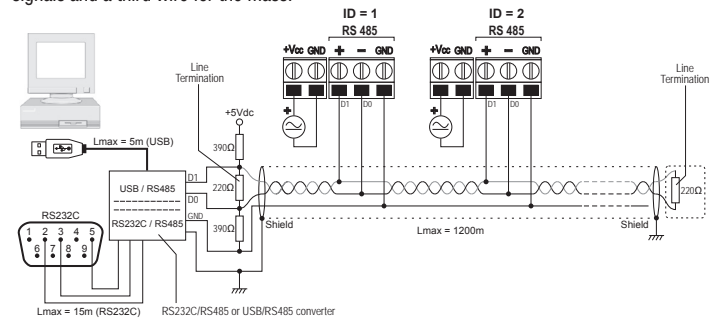

Line termination must be set at the two network ends. To polarize the line during non-transmission periods, resistors are connected between signal and power supply lines.

The maximum number of devices that can be connected to the (Bus) line RS485 depends on the load characteristics of the devices to be connected.

The standard RS485 requires that the total load does not exceed 32 Unit Loads. The load of a HD48S.. transmitter is equal to 1/4 of the unit load.

If the total load is more than 32 unit loads, divide the net in segments and insert a signal repeater between one segment and the next one. At the beginning and at the end of each segment a line termination must be connected.

The instrument has a built in line termination that can be connected or removed through a short jumper placed next to the terminal block. If the instrument is the last or the first device of a network group, connect the termination placing the short jumper between the "RT" and "240 ohm" indications. If the instrument is not at the end of a network group, remove the termination placing the short jumper between the "RT" and "OPEN" indications.

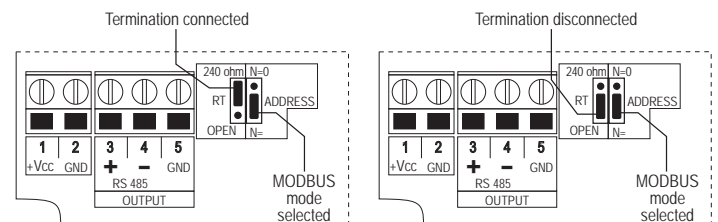

The cable shield must be connected to both line ends. The cable should have the following features:

- Characteristic impedance: 120 ohm
- Capacity: less than 50pF/m
- Resistance: less than 100 ohm/km
- gauge: 0,22 mm² (AWG24) at least.

The cable maximum length depends on baud rate and cable characteristics. Typically, the maximum length is 1200m. The data line must be kept separated from any power lines in order to prevent interferences on the transmitted signal. For connection to a PC, a RS232/RS485 or a USB/RS485 converter must be used. To operate with the MODBUS-RTU protocol be sure that the ADDRESS short jumper is between "ADDRESS" and "N=" indications.

Each transmitter of the network is univocally identified by an address. The address must be between 1 and 247. **There must not be any other transmitters connected with the same address.** The address must be configured before connecting the instrument to the network. To set the instrument address use the **HD48STCAL** kit. The kit includes the **RS48** cable with built in USB/RS485 adapter and a CD-ROM for Windows® operating systems. To configure the instrument it is necessary to move the ADDRESS short jumper between the "ADDRESS" and "N=0" indications to select the setup mode. After the configuration, move the short jumper back between the "ADDRESS" and "N=" indications.

In MODBUS mode it is possible to read the measured values by the instrument through the 04h functioning code (Read Input Registers). Table 2 represents the available quantities with its relative register address.

Table 2 – Modbus Registers

| Address | Quantities | Format |
|---------|---|-----------------|
| 0 | Temperature in °C (x10) | Complete 16 bit |
| 1 | Temperature in ° (x10) | Complete 16 bit |
| 2 | Relative Humidity in % (x10) | Complete 16 bit |
| 3 | Dew Point in °C (x10) | Complete 16 bit |
| 4 | Dew Point in °F (x10) | Complete 16 bit |
| 5 | State register Bit 0 = 1 → temperature measure in error Bit 1 = 1 → relative humidity measure in error Bit 2 = 1 → dew point temperature calculation in error Bit 3 = 1 → error in data configuration | Complete 16 bit |

HD49.. series

Follow the connection schemes shown below, the maximum load resistance that can be connected to each 4...20mA output depends on the power supply Vcc applied, according to the relation:

$$R_{L\text{Max}} = (V_{dc} - 12) / 0.022, \text{ e.g. if } V_{dc} = 24V_{dc} \text{ the max load is } R_{L\text{Max}} = 545 \text{ ohm.}$$

HD4917T...

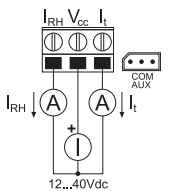

HD4977T...

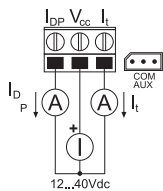

HD4901T...

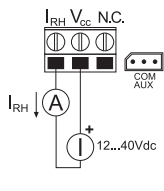

HD4907T...

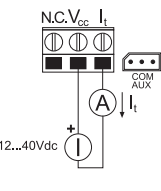

Relative humidity probe calibration

The HD48.. and HD49.. transmitters are supplied factory calibrated and ready to use. If necessary, it is possible to calibrate the relative humidity sensor using the saturated salt solutions **HD75** (75% RH saturated salt solution) and **HD33** (33% RH saturated salt solution) by connecting the instrument to the PC and using the HD48TCAL software.

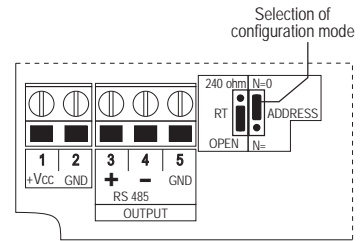
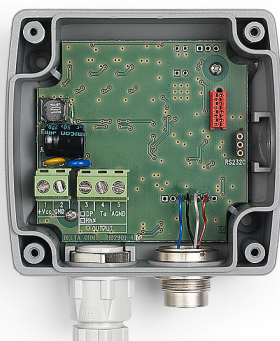
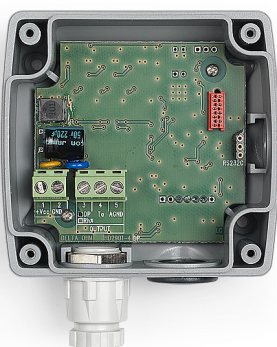

Case dimensions

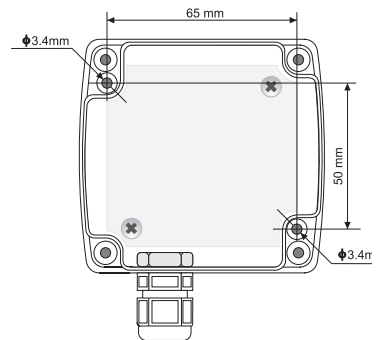
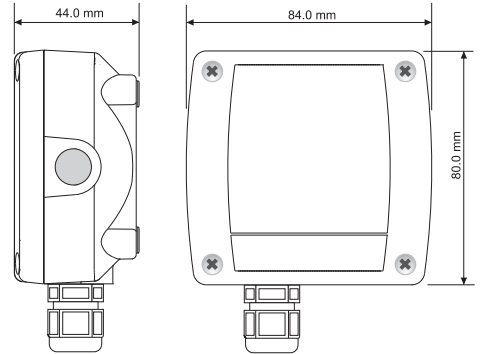

Probe dimensions: T0 series

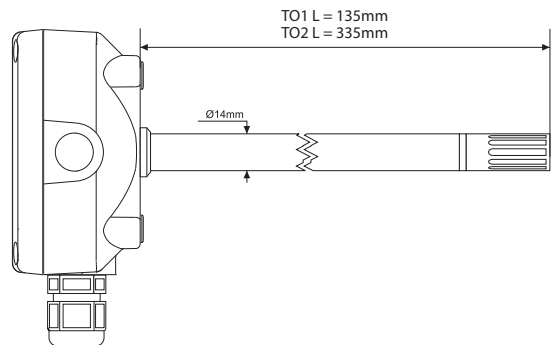

TC series

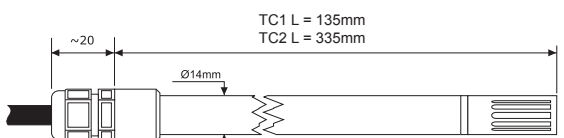
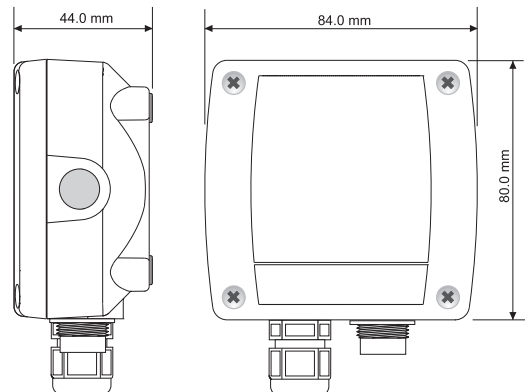

Ordering codes

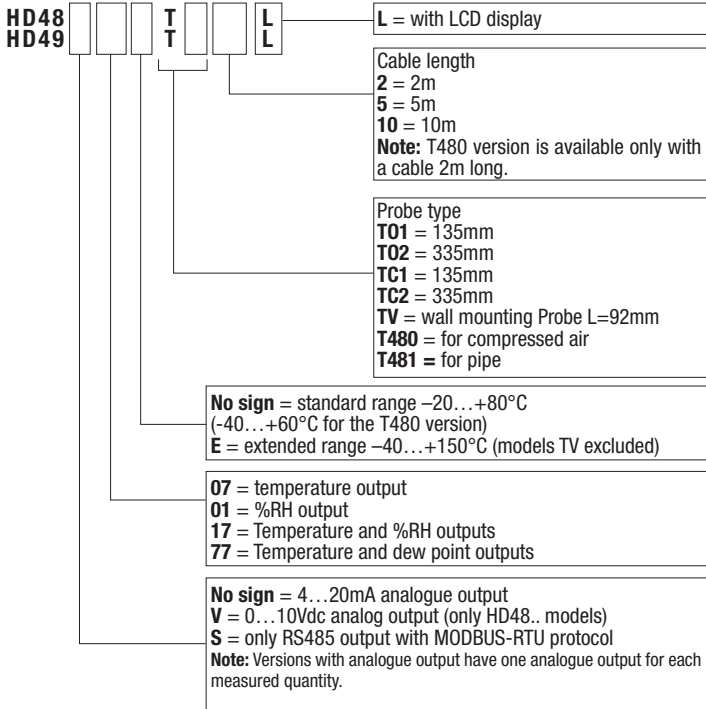

TV series

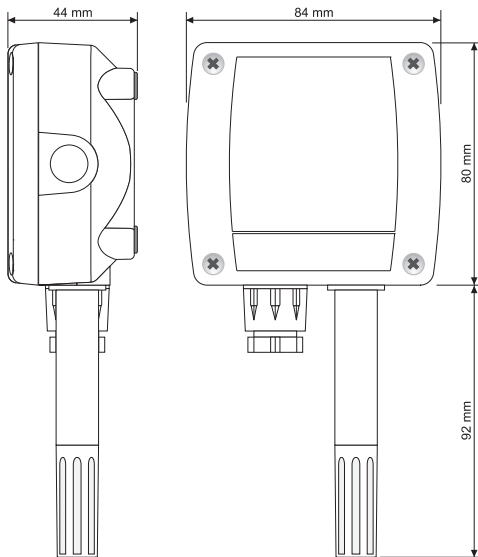

Ordering code examples

HD4801TV: Wall mounting digital active relative humidity transmitter.

Relative humidity range 0...100%RH.

Analog output: 4...20mA (0...100%RH).

Probe working range -20...+80°C. Power supply 18...40Vdc or 24Vac.

HD4917T01: Digital passive (current loop) temperature and relative humidity transmitter for duct mounting. AISI304 steel probe, diameter 14mm and stem length 135mm, joined to the electronics enclosure.

Relative humidity range 0...100%RH, temperature range -20...+80°C.

Analog outputs: 4...20mA (0...100%RH) for RH and 4...20mA (-20...+80°C) for temperature. Probe working range -20...+80°C. Power supply 12...40Vdc.

HD4817TC25L: Digital active temperature and relative humidity transmitter with LCD display. AISI304 steel probe, diameter 14mm and stem length 335mm, connected to the electronics enclosure through a 5m cable.

Relative humidity range 0...100%RH, temperature range -20...+80°C.

Analog outputs: 4...20mA (0...100%RH) for RH and 4...20mA (-20...+80°C) for temperature. Probe working range -20...+80°C. Power supply 18...40Vdc or 24Vac.

HD48V17ETC25: Digital active temperature and relative humidity transmitter, extended range. AISI304 steel probe, diameter 14mm and stem length 335mm, connected to the electronics enclosure through a 5m cable.

Relative humidity range 0...100%RH, temperature range -40...+150°C.

Analog outputs: 0...10V (0...100%RH) for RH and 0...10V (-40...+150°C) for temperature. Probe working range -40...+150°C. Power supply 18...40Vdc or 24Vac.

HD48S17TC25L: Digital active temperature and relative humidity transmitter with LCD display. AISI304 steel probe, diameter 14mm and stem length 335mm, connected to the electronics enclosure through a 5m cable.

Relative humidity range 0...100%RH, temperature range -20...+80°C.

Only RS485 output with MODBUS-RTU protocol. Probe temperature working range -20...+80°C. Power supply 18...40Vdc or 24Vac.

HD4877T02: Digital active temperature and dew point transmitter for duct mounting. AISI304 steel probe, diameter 14mm and stem length 135mm, joined to the electronics enclosure.

Dew point range -20...+80°C DP, temperature range -20...+80°C.

Analog outputs: 4...20mA (-20...+80°C DP) for DP and 4...20mA (-20...+80°C) for temperature. Probe working range -20...+80°C. Power supply 18...40Vdc or 24Vac.

HD4977T02: Digital passive (current loop) temperature and dew point transmitter for duct mounting. AISI304 steel probe, diameter 14mm and stem length 335mm, joined to the electronics enclosure.

Dew point range -20...+80°C DP, temperature range -20...+80°C.

Analog outputs: 4...20mA (-20...+80°C DP) for DP and 4...20mA (-20...+80°C) for temperature. Probe working range -20...+80°C. Power supply 12...40Vdc.

Accessories

RS48: Cable for RS485 serial connection with built-in USB/RS485 converter.

CP27: Connection/converter cable from COM AUX serial port to USB.

HD75: 75% RH saturated solution for the verification of the relative humidity sensor, complete of screw adaptors for probes with \varnothing 14mm and \varnothing 26mm.

HD33: 33% RH saturated solution for the verification of the relative humidity sensor, complete of screw adaptors with \varnothing 14mm and \varnothing 26mm.

HD9008.31: Wall flange with cable gland to fix \varnothing 14mm probes.

PG16: AISI304 steel cable gland for \varnothing 14mm probes.

P6: 10 μ sintered stainless steel protection for \varnothing 14mm probes.

P7: 20 μ PTFE protection for \varnothing 14mm probes.

P8: Stainless steel grid 20 μ and Poca for \varnothing 14mm probes.

